



**SOUND
BOARD®**

VENUE RIDER

February 2, 2022

Mohegan City
CASINO · HOTEL

MOTORCITY CASINO HOTEL

MAILING & SHIPPING:

MotorCity Casino Hotel
Attn: Entertainment
2901 Grand River Avenue
Detroit, Michigan 48201

THEATER NAME: Sound Board

IN HOUSE BOOKING AGENCY: Olympia Entertainment

WEB PAGES: MotorCityCasino.com
SoundBoardDetroit.com

MAIN PHONE NUMBER: 313-237-7711

ENTERTAINMENT OFFICE: 313-309-4690

ENTERTAINMENT FAX: 313-309-4680

BOX OFFICE PHONE: 313-309-4700

BOX OFFICE FAX: 313-309-4695

GROUP SALES/SPECIAL NEEDS TICKETING: 313-309-4614

SOUND BOARD PRODUCTION OFFICE: 313-309-4682

SOUND BOARD PRODUCTION OFFICE FAX: 313-309-4684

ENTERTAINMENT TEAM

Bill Borenstein, Vice President of Entertainment
MotorCity Casino Hotel, Sound Board
bborenstein@mccemail.com, 313-309-4561

Maggie McCarthy, Entertainment Manager
[Box Office and Event Staff Management]
mmccarthy@mccemail.com, 313-309-4690

Jasmine Geary, Entertainment Manager
[Artist Hotel and Hospitality Advance]
jgeary@mccemail.com, 313-237-6737

Mario Consiglio, Production Manager II
mconsiglio@mccemail.com, 313-237-6717

Kevin White, Production Manager II
kwhite@mccemail.com, 313-309-4579

FOR ALL ARTIST TOUR ADVANCE NEEDS INCLUDING PARKING, HOTEL, F&B, AND SECURITY, PLEASE CONTACT JASMINE GEARY.

All shows to be advanced a minimum of two weeks prior to the show date.

TICKET PURCHASES

SOUND BOARD BOX OFFICE

Location: 2nd floor, by Sweet Ride coffee shop

Hours:

Wed: 3pm-8pm

Fri: 5pm-9pm

Sat: 3pm-8pm

Sun: 11am-4pm

Opens at 3pm on event days

Summer Hours: (Jun-Aug)

Sat: 3pm-8pm

Sun: 11am-4pm

Opens at 3pm on event days

TICKETMASTER

[ticketmaster.com](https://www.ticketmaster.com)

Venue link for artist/promoter link purposes only:

[ticketmaster.com/venue/66095](https://www.ticketmaster.com/venue/66095)

SEATING CAPACITIES

1,595 Fully Seated

1,527 Fully Seated w/o Orchestra Seats

2,372 Balcony Seated/Floor/Mezz/Orch General Admission Standing

1,635 Boxing/MMA

460 Banquet

SOUND BOARD BARS

100 Level, two total, behind Sections 110 and 150.

(100 Level bars are visible from the stage.)

200 Level, two total, behind Sections 220 and 250

(Outside 100 and 200 Levels in outer lobbies.)

Additional portable bars are added as needed.

SOUND BOARD MERCH

100 Level behind Section 120. This is a permanent location, visible from the stage.

A secondary location can be set up as designated by MotorCity Casino Hotel in the 200 Level outer lobbies, using a designated MotorCity Casino Hotel kiosk.

Seller should make provisions for wireless credit card machines.

VENUE POLICIES

COVID-19 POLICY: Please visit [SoundBoardDetroit.com](https://www.soundboarddetroit.com) for our Covid-19 guidelines.

ADMITTANCE: All guests must have a valid ticket to enter Sound Board and are subject to search and successful pass through a metal detector. Artists and Artist's personnel must be credentialed in order to enter Sound Board or any designated back-of-house area. Venue credentials are available upon request.

ADA: ADA Accessible seating AND ticket purchases are available through Ticketmaster. Please contact us at (313) 309-4614 for special need requests, including interpreting services and assisted listening devices.

CONVENTION SPACE: Adjacent convention space is available for party rentals during all concert events. Live Show Video and Audio is simulcast in the casino, all VIP boxes, and adjacent convention meeting rooms when utilized in conjunction with concerts.

CCTV: MotorCity Casino Hotel is licensed by the State of Michigan Gaming Control Board; CCTV is required throughout the facility.

DOORS: House opens a minimum of 60 minutes prior to the show start time.

FOOD & BEVERAGE: All food and beverage must be provided by MotorCity Casino Hotel; no outside food or beverage is permitted.

GUEST LISTS: Artist guest lists are requested two hours prior to the performance start time.

GROUP SALES: Group ticket sales, for ticket purchases of 20 or more tickets, are available for select events through the Sound Board Box Office. Call (313) 309-4614 for assistance.

ITEMS NOT PERMITTED: Weapons, restraining devices, laser pointers, and/or additional items as determined by MotorCity Casino Hotel.

MARKETING/ADVERTISING: Only approved logos provided by MotorCity Casino Hotel may be used on artist advertisements, promotions and/or web pages. Please contact us for a high resolution logo file. MotorCity Casino Hotel Marketing must approve all logo placement/use prior to production.

MERCHANDISE: Approved merchandise may be sold at designated MotorCity Casino Hotel Sound Board locations. Rate is per contract. Artist is responsible for payment of all taxes and credit card fees associated with the sale of merchandise.

RECORDING: Use by guests of recording devices of any type is NOT permitted. Artists wishing to record performances must receive prior approval by MotorCity Casino Hotel.

RUNNERS: MotorCity Casino Hotel does not provide runners but can assist in locating services to be paid by artist directly.

GUEST POLICIES

COVID-19 POLICY: Please visit [SoundBoardDetroit.com](https://www.soundboarddetroit.com) for our Covid-19 guidelines.

AGE: Guests must be at least 21 years old to attend shows unless specific exemption is given for a designated show.

BEVERAGES: Beverage service provided by MotorCity Casino Hotel is permitted during designated performances.

EVACUATION: Events will stop and Sound Board will be evacuated if a fire alarm is activated or upon notification from the Security Director or Manager on Duty.

FOOD: Outside food is not permitted unless deemed medically necessary.

NOT PERMITTED: Weapons, restraining devices, laser pointers, and additional items as determined by MotorCity Casino Hotel are not permitted inside Sound Board.

PASS OUTS: Pass outs are permitted via the 1st floor convention center entrance.

PHOTOGRAPHY: Flash photography is NOT permitted. Media photographers must be credentialed and must adhere to artist and MotorCity Casino Hotel policies.

RECORDING: Guest use of recording devices of any type is NOT permitted.

SEARCH: Prior to entering Sound Board, all guests must pass through metal detection devices and/or are subject to search as required by MotorCity Casino Hotel Security.

SMOKING: Smoking is NOT permitted.

TECHNICAL INFORMATION

LOAD-IN: Sound Board loading dock (covered) at Brooklyn and Spruce streets. One truck at a time; dock plate provided.

Access to stage by roll-up door; dimensions:
(H) 10' 6" x (W) 14'

Case storage on receiving dock: 30' x 30'

Car ramps: 14' length, 12,000 lbs per axle

BUS/TRUCK PARKING: Next to stage loading dock.

Shore Power available. Distance to Shore Power: 100' (four provided)

Power: 5@ 50amp RV Hook-Up

POWER: 100 amp 3P 120/208 cam lock tie in: Down Stage Right
400 amp 3P 120/208 cam lock tie in: Down Stage Right
200 amp 3P 120/208 cam lock tie in: Down Stage Left
200 amp 3P 120/208 cam lock tie in: Up Stage Left
Stage right: Isolated Ground/ Stage left: Building Ground

All power connect and disconnect MUST be performed by MotorCity Casino Hotel personnel.

TOTAL SQUARE FOOTAGE: 23,500 sq ft.

OUTSIDE PATHS: 3 8" cable troughs located up stage left

STAGE: Working stage: 50' 6" W x 21' D
If orchestra stage extension is used: 50' 6" W x 29' 9" D Stage height: 5' 5". House does not own a stage barricade. Elevation of stage over "mix level" is approximately 5'.
Floor: Harlequin Cascade, black Stage Weight Load: 100lbs. per sq. ft.
Extension Weight Load Fixed: 65,375 lbs. total Extension Weight Load Moving: 26,375 lbs. total
Fixed front of stage is straight.

STAGE DETAIL: Proscenium arch width: 50' 6" Proscenium arch height: 27' at center Main curtain line to back curtain/CYC: 17' Fixed stage to back curtain/CYC: 21' Fixed stage to main curtain line: 4'
Orchestra stage to main curtain line: 12' 9" Orchestra stage to back curtain/CYC: 29' 9"

RIGGING

STAGE: # of stage points: 8 Load: See plot
Current lighting truss locations: See plot
All stage rigging points in use for house goods and lights.

HOUSE: # of stage points: 14 Load: See plot
Current Lighting Truss Locations: See plot
Contact production manager for available point locations.

Additional rigging requires MotorCity Casino Hotel approval, signed and sealed drawings submitted a minimum of 14 business days prior to the event, and MotorCity Casino Hotel-approved engineering firm's review and approval, at sole cost to producer/production company.

STEEL

FROM PIT FLOOR: High steel 62'
Low steel 50'

FROM STAGE: High steel 56' 5"
Low steel 44' 5"

MAIN CURTAIN

HAND DRIVEN COLOR: Blue

TYPE: Traveler, no center overlap

HOUSE GOODS

UPSTAGE: One (1) fixed CYC/scrim (white)

UPSTAGE: One (1) black traveler (in front of CYC/scrim) Wing black-outs: Black travelers

RISERS: Various height configurations available

STAGE RIGHT: 4' x 8' reversible black gray tech stage carpet Sico 6' x 8' black carpeted

LIFT: Genie AWP40S

SMOKE/HEAT FIRE DETECTION DEVICES: Sound Board has a mixture of smoke and heat detection devices as required by the City of Detroit and the State of Michigan. Disabling, disarming, or tampering with these devices is strictly prohibited.

MotorCity Casino Hotel is not permitted, at any time or for any reason, to disarm the Fire/Life safety systems.

Only water-based hazers or foggers are permitted inside Sound Board.

VIP BOXES: Sound Board has two VIP boxes that are used for every event. Both boxes include live video and audio feeds.

STAGE BOX: Located on the 200 Level, stage left, backstage
Stage Box is located backstage.

SKY BOX: Located on the 200 Level, house left, front of house

Both boxes are glass enclosed and include simulcast live video and audio feeds.

FACILITIES

PRODUCTION OFFICE: Stage left Dimensions: 13' 2" x 9' 7"

EQUIPMENT: One dedicated phone line One dedicated fax line
Phone numbers advanced directly
One fax/copy/printer. Printer available via network cable.
One LCD TV with DIRECTV and house program feed

DRESSING ROOMS

STAGE LEFT: One quick change dressing room with bathroom/shower Dimensions: 7' 6" x 12' 2"

STAGE RIGHT: One star dressing room with bathroom/shower Dimensions: 12' 10" x 15' 7" [DR: A]

TWO DRESSING ROOMS WITH PRIVATE RESTROOMS DIMENSIONS: Dressing Room B: 12' 10" x 17' 7"
Dressing Room C: 10' 7" x 14' 4"

A unisex restroom is located in the dressing room area.

All dressing rooms have mirrors, furniture, telephone, refrigerator, and an LCD TV with DIRECTV and house program feed.

LAUNDRY

STAGE RIGHT WASHER: Whirlpool WTW8500DCO 5.3 cu. ft. Cabrio® high-efficiency top load washer

DRYER: Whirlpool WED8500DCO 8.8 cu. ft. Cabrio® high-efficiency electric steam dryer

INTERNET

Free wireless internet is provided for all theater production and dressing room areas. Dedicated wired and wifi available with various speed options.

STAGE PLAN

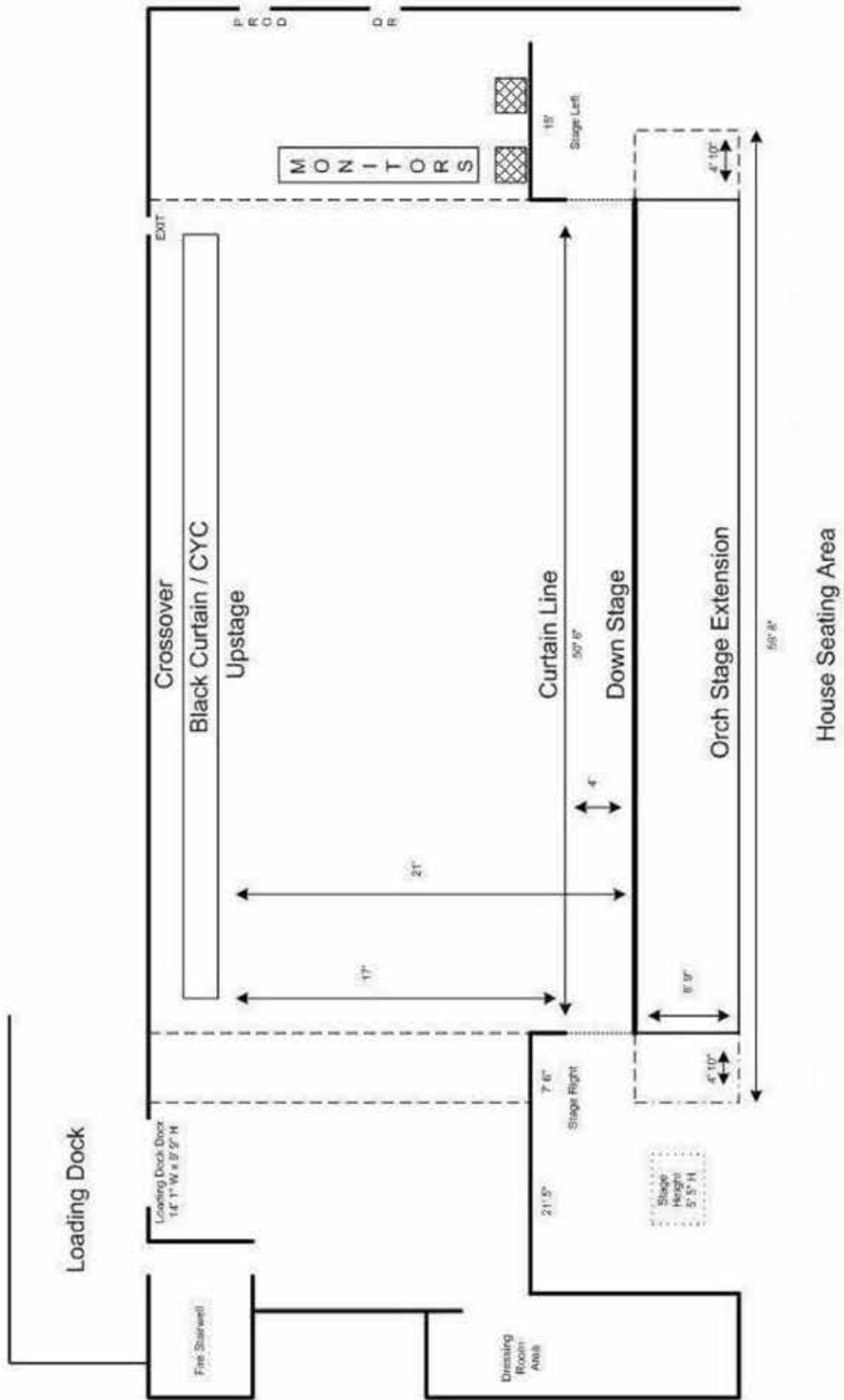

STAGE RIGHT FLOOR PLAN

Dressing Rooms

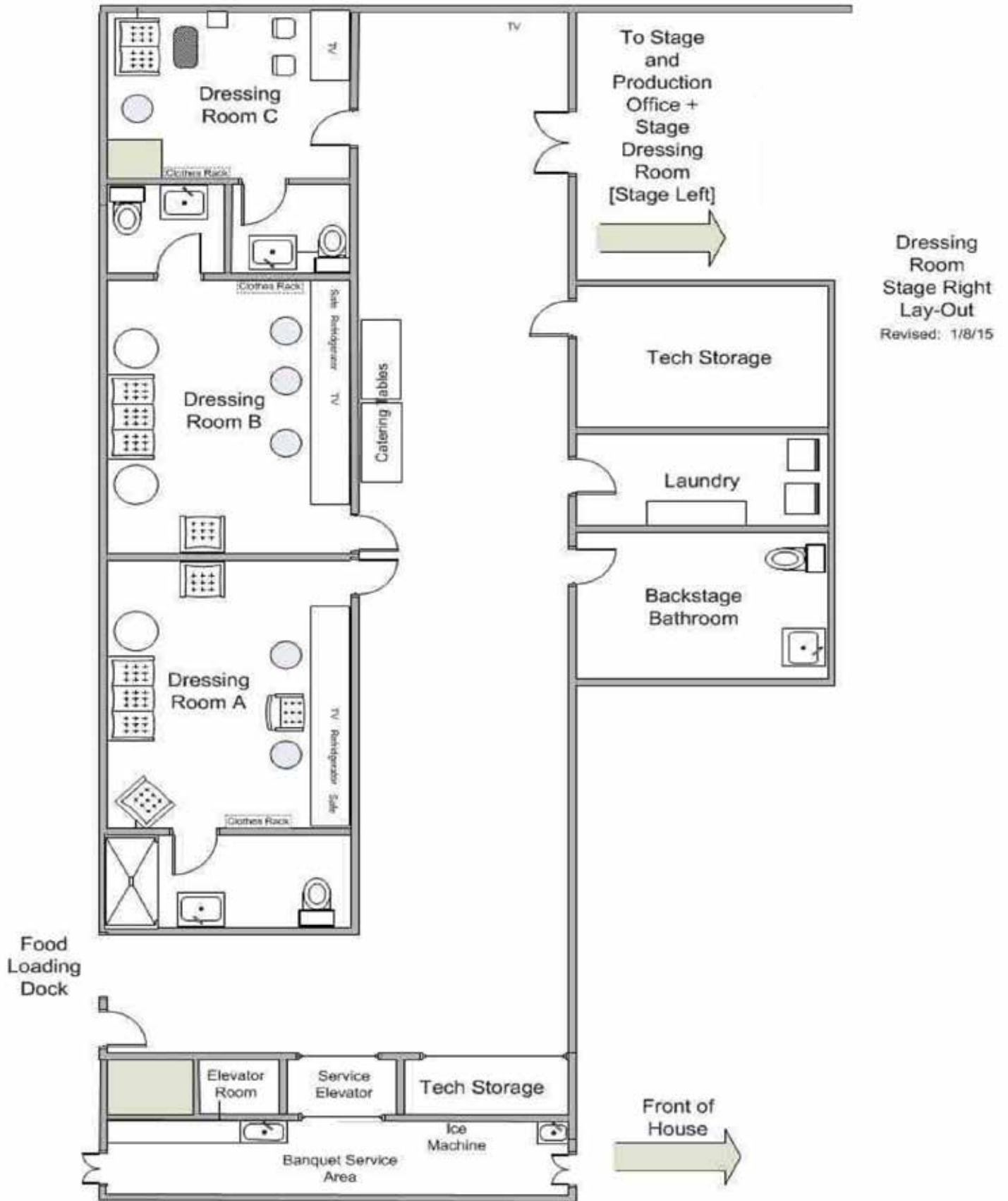

STAGE LEFT FLOOR PLAN

Production Office and Quick Change

Stage Left
Lay-Out

Revised: 7/1/11

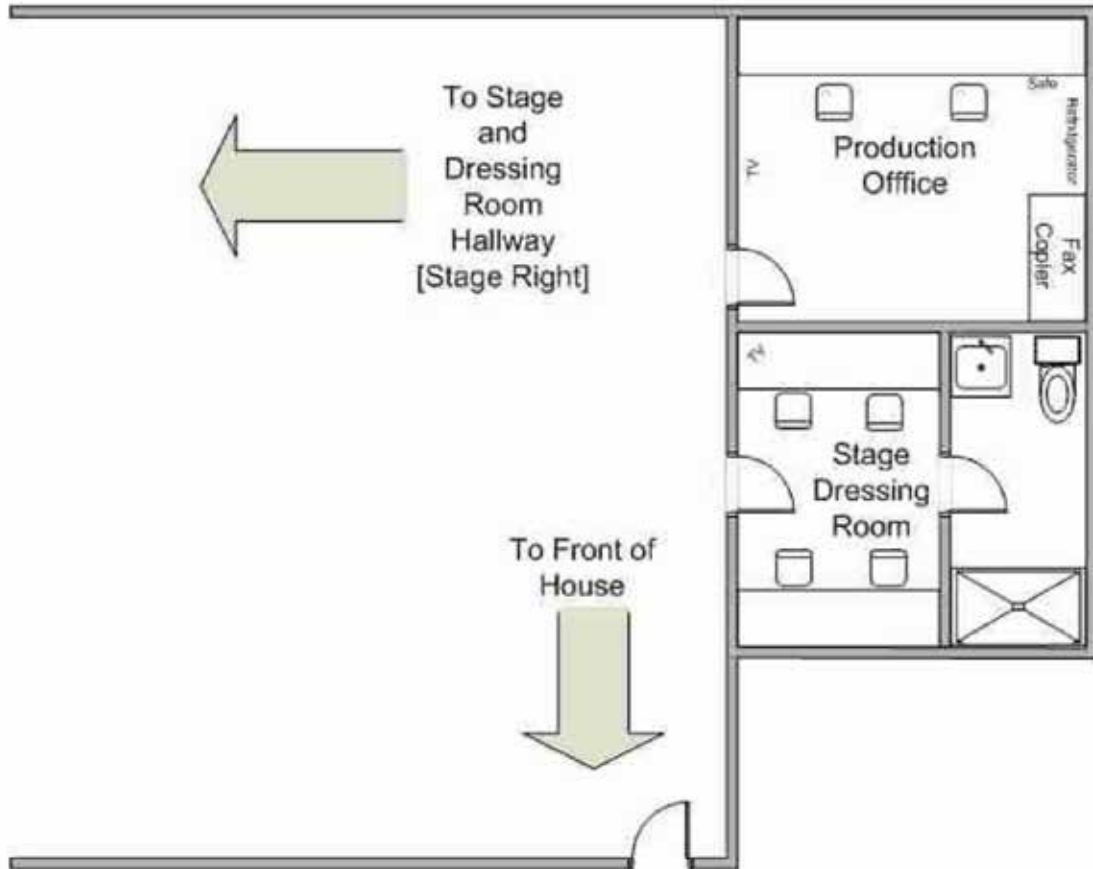

MAIN FLOOR DIMENSIONS

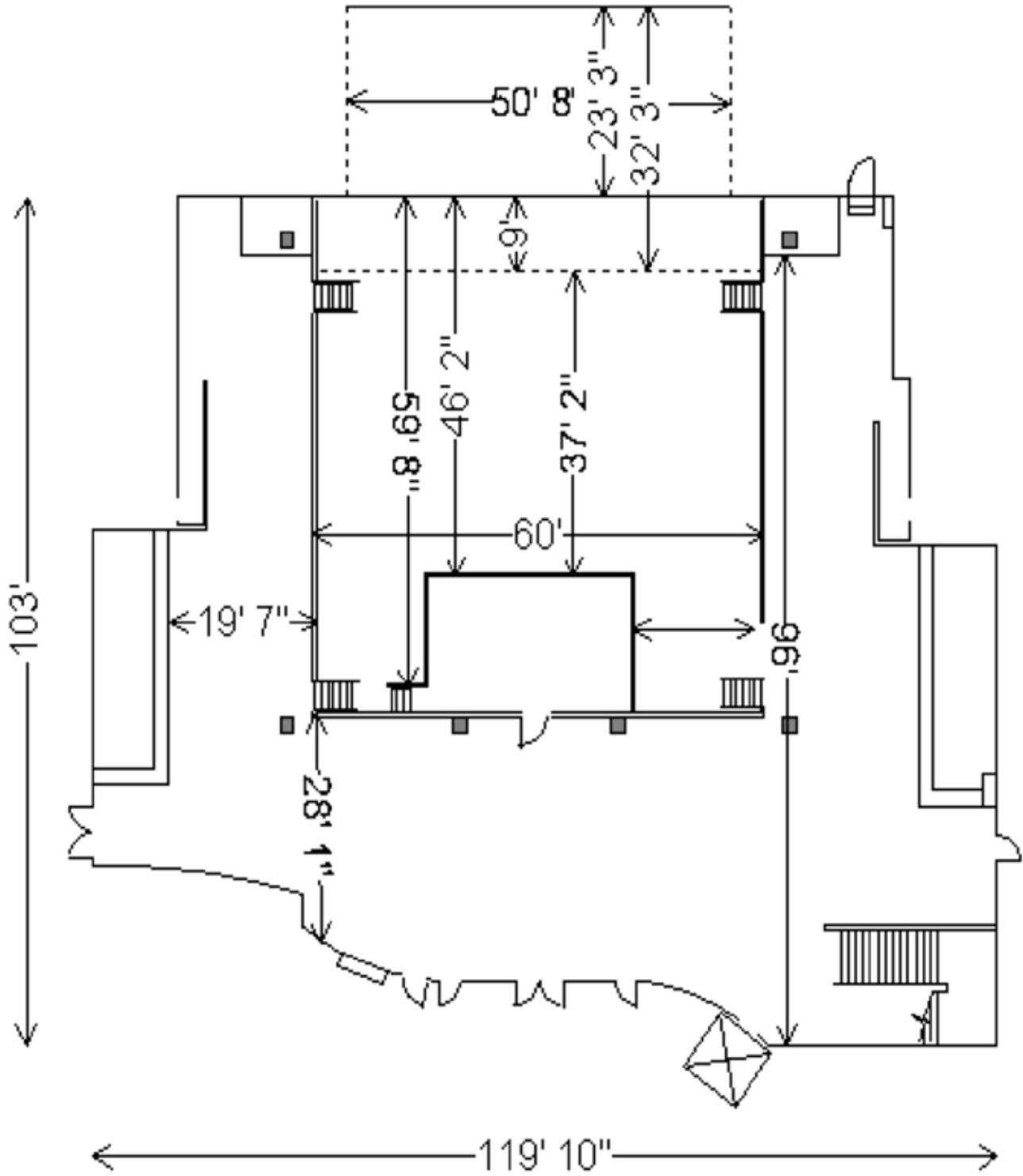

RIGGING POINTS

ROOF PURLIN LOADING DIAGRAMS (NOTE 3)

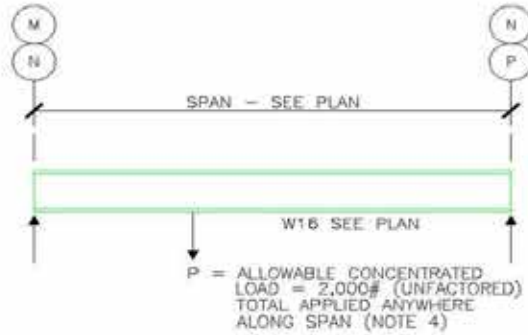

THEATRE AREA PURLIN

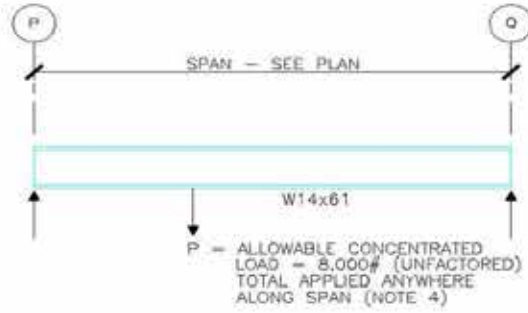

THEATRE AREA PURLIN

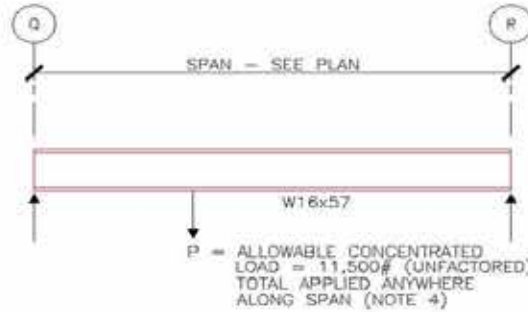

STAGE CENTER PURLIN

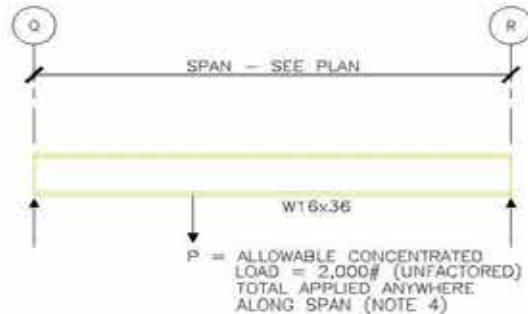

STAGE LEFT & RIGHT PURLIN

TRUSS SPECS

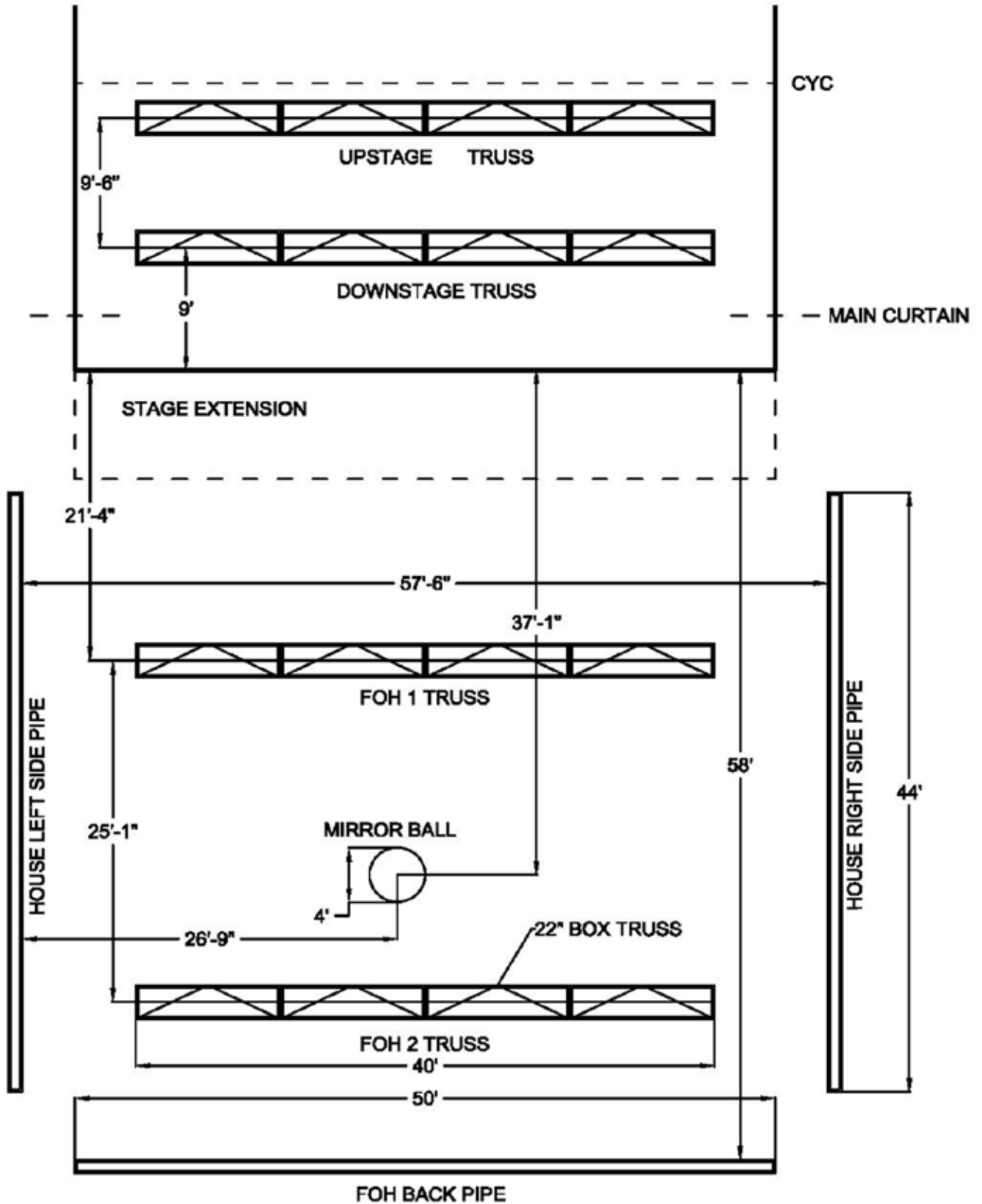

AUDIO

FOH MIXING/CONTROL LOCATION: The front-of-house mix location is orchestra level, 50' from stage, 41' if orchestra extension stage is used, housing the sound, video, and lighting control areas, and measures 24' wide and 12' deep. It is a raised platform 7" above the seated "pit" area or 28" above the standing "pit" area. Tour sound, lights, and video will use this location if providing own boards. *Live Show Video and Audio is simulcast in the casino, all VIP boxes and adjacent convention meeting rooms when utilized in conjunction with concerts.*

MAINS SPEAKER SYSTEM: The Mains Speaker system consists of left and right line array clusters utilizing d&b J- Series line array elements flown on 2-ton chain motors situated either side just outside the proscenium.

CLUSTER SPECIFICATIONS (EACH):

10	d&b	J-8 3 way line array elements
3	d&b	J-Sub Cardioid line array subwoofer elements
2	d&b	J-series flying frames
2	CM	Loadstar 2 ton chain hoists

CLUSTER POWER (EACH): 8 d&b D-12 processed amplifiers with AES input

STAGE SUBWOOFERS: There are 3 d&b B-2 subwoofers either side of the stage (6x B-2 subs total) located on the floor directly below each cluster powered by 4 d&b D-12 amplifiers.

FRONT FILLS: 4x d&b Q-7 speakers powered by 1 x d&b D-12 amplifier

OUT-FILLS: 2x d&b Q-7 speakers powered by 1 x d&b D-12 amplifier

BALCONY FILLS: 2x d&b Q-7 speakers powered by 1 x d&b D-12 amplifier

BALCONY DELAY: 2x d&b Q-7 speakers powered by 1 x d&b D-12 amplifier

1ST FLOOR UNDER BALCONY FILLS: 8x d&b E-8 speakers powered by 2x d&b D-6 amplifier (on delay)

FRONT OF HOUSE: The house mix console is a Yamaha Rivage PM7

CONSOLE SPECIFICATIONS: 64 mic inputs (plus 8 mono TRS inputs) total 72 inputs

- 64 mic inputs
- 16 stereo effect returns
- 60 buses
- 24 matrices
- 5 AES/8 channel output card
- 2 Analog/16 channel output card
- Dynamics processing on each channel
- 48 assignable graphic EO's
- 48 assorted plugins including Rupert Neve

MAINS FOH ACCESSORIES: 3 Lake processors for FOH matrix and sub-matrix control
Twin Lane in/out inserted into console matrix outputs

1-360 Systems Instant Replay 2
1-Whirlwind Press Mite 1 In/12 mic out & 2 line out
1-8 Channel Multi XLR In/Out hard wired box at FOH
1-ASUS Xonar Essence One
64 Channel Dugan

*Note: A complete digital signal chain is maintained from the stage box input converters through the console, through the Dolby Lake EO's to the amplifier AES inputs.
Under stage snake trough with pull rope for guest run available*

MONITORS: The monitor mix console is a Yamaha Rivage PM7. It is located stage left.

Console specifications:
64 mic inputs
16 stereo effect returns
60 buses
24 matrices
8 stereo matrices
1 analog/16 channel output card
1 AES/16 channel A-Net output card
Dynamics processing on each channel
48 assignable graphic EO's
48 assorted plugins including Rupert Neve

MONITOR ACCESSORIES: 1-Tascam CD-01U CD Playback

MONITOR SPEAKER SYSTEMS: 8 d&b M2 2-way active floor wedge monitors
8 d&b M4 2-way active floor wedge monitors
2 d&b Side Fills Top: C7 (1x15x2)/Bottom (2) C-Sub (1x18)
2 OSC Drum Sub KW 181

STAGE SPLIT SYSTEM: To maintain independent FOH and monitor mic-pre adjustment a 56-input Jensen transformer mic splitter is used to split all analog mic signals to two independent stage racks. A third isolated split is available for TV truck applications. 1-16 channel split snake to accommodate larger input requirements.

INTERCOM SYSTEM: Clear-Com intercom system for sound, lights and video intercom; 10 wired stations and 6 wireless stations available; 1-HL, 1-HR, 2-followspots, 5-FOH, 1-stage entrance.

AUDIO MONITORING & PAGE SYSTEM: Backstage monitors in all dressing rooms, hallways and production offices. Paging from multiple locations.

MICROPHONE INVENTORY:

Qty.	Make/Model
2	AKG 414
2	AKG C214
4	Sennheiser A421
6	Sennheiser E604
4	Sennheiser E609
2	Sennheiser 835s
6	Shure SM57
6	Shure SM58
6	Shure SM81
6	Shure Beta57A
6	Shure Beta58A
3	Shure Beta52A
2	Shure Beta91A
5	Shure Beta98
10	Radial JD1
4	Radial Pro48
1	Radial JDC Stereo
2	Radial Pro D8
1	Whirlwind PCDI
12	Shure Axient G1 470-530 Handheld/Lav Combo
12	Shure Beta 58A capsules
2	Shure KSM8 capsules
2	Shure KSM9 capsules

2016 ACOUSTIC SURVEY OF SOUND BOARD (SUMMARY)

TEST SYSTEM: IRIS 3D Impulse Response System

SOURCE: Full house PA system

RECEIVER: 4-channel calibrated sound field microphone

VENUE BACKGROUND NOISE (HVAC SYSTEM ON):

NC 32

RC 33N

40 Dba

VENUE AVERAGE REVERBERATION TIME - T30 (SEC) UNOCCUPIED:

63 Hz - 125 Hz | 250 Hz- 2 KHz | 500 Hz-8 KHz

Mix Position	1.3	1.0	0.9
Lower Level Average	1.4	1.0	0.9
Bar level Average	1.4	1.0	0.9
Upper Level Average	1.4	1.0	0.9

VENUE AVERAGE CLARITY - C80 (Db) UNOCCUPIED:

63 Hz - 125 Hz | 250 Hz- 2 KH | 500 Hz-8 KHz

Mix Position	-2.5	6.8	9.7
Lower Level Average	5.0	9.5	11.4
Bar level Average	3.7	7.3	9.2
Upper Level Average	1.6	6.9	8.7

VIDEO

VIDEO CONTROL LOCATION: The front-of-house mix location is orchestra level 50' from stage (41' if orchestra extension stage is used), housing the sound, video, and lighting control areas, and measures 24' wide and 12' deep. It is a raised platform 7" above the seated "pit" area or 28" above the standing "pit" area. Tour sound, lights, and video will use this location if providing own boards.

VIDEO SIMULCAST: Live show video and audio are simulcast in the casino, all VIP boxes, and adjacent convention meeting rooms when utilized in conjunction with concerts.

VIDEO EQUIPMENT:

- 2 Vaddio RoboShot 30 HD Cameras with remote (Vaddio) Production View Precision camera controller including pan/tilt/zoom controls
- 2 MultiView 22" Sony Monitors
- 1 BlackMagic ATEM 2M/E Broadcast Studio 4K switcher
- 1 BlackMagic ATEM 2M/E Broadcast panel
- 1 BlackMagic Design 12x12 Smart Video Hub with BMD master controller
- 1 BlackMagic Design multi dock
- 1 JVC SR-HD1500 Blu-Ray player
- 2 BlackMagic HyperDeck SSD record decks
- 1 Mac Pro (27" thunderbolt display) with Final Cut Pro and Playback Pro
- 1 Dell 9020 i7 PC with Microsoft Office 365 suite
- 1 DIRECTV HD satellite box
- 1 Crestron OM 32x32 4K digital routing matrix for venue control
- 1 BlackMagic Design 20x20 Smart Video Hub with BMD master controller

VIDEO PROJECTION:

- 1 Panasonic PT-DZ21 KU HD video projector, 20K lumen (center)
- 2 Panasonic PT-DZ16KU-HD video projectors, 16K lumen Dedicated projectors

Center projection screen: CYC/scrim 30' W x 20' H (scalable projection) or
Center screen 24' W x 13' 6" H in front of main curtain

Stage right and left projection screens: 16' W x 9' H screens on 200 Level

Notes: All screens are front projection.
All above screens are motorized except CYC/scrim.

ADDITIONAL FOH PROJECTION(STAGE LEVEL PORTABLE):

- 2 Panasonic PT-RZ1 2KU lasers 12K lumen
- 2 Da-light fast fold screens 6' H x 9' W with blue dress kit

FIXED MONITORS:

- 2 Panasonic 75" plasma displays (HD) with HDMI inputs*
- 10 Panasonic 50" plasma displays (HD) with HDMI inputs*
- 4 Panasonic 58" plasma displays (HD) with HDMI inputs*
- 1 Panasonic 42" plasma display (HD) with HDMI inputs*
- 2 Panasonic 65" LED displays (HD) with HDMI inputs*

**For use as orchestra/balcony front displays, bar displays, theater entrance displays and VIP area displays. All plasmas are permanently installed.*

CONFIDENCE MONITORS: Available upon request.

CCTV MONITORING SYSTEM: Backstage video monitors in all dressing rooms, hallways, and production offices
HD CATV system and Sound Board program feed.

OTHER PRESENTATION EQUIPMENT

ADDITIONAL EQUIPMENT:

- 2 DSAN Limitimer PRO-2000BT
- 2 PowerPoint remotes
- 1 Micro Cue² with 2 remotes
- 1 DSAN Perfect Cue with 2 remotes

LIGHTING

LIGHTING CONTROL LOCATION: The front-of-house mix location is orchestra level 50' from stage (41' if orchestra extension stage is used), housing the sound, video, and lighting control areas, is 24' wide and 12' deep. It is a raised platform 7" above the seated "pit" area or 28" above the standing "pit" area. Tour sound, lights, and video will use this location if providing own boards.

CONSOLE: HES Road Hog Full Boar console has 2 15.6" color touch screen monitors, 10 playback faders with programmable Road Hog wing 1 15.6" multi-touch screen monitor, and 10 motorized play back faders.

LIGHTING FIXTURES:

- 12 HES Solaframe 1500
- 12 HES Solaspot 1000
- 9 HES Color Command 750
- 10 HES Techno Arc
- 8 ACL units
- 10 Martin MAC Viper AirFX III
- 9 Color Kinetics Color Blaze
- 8 Elation Colorado 3-Panel LED
- 1 LED Arch proscenium (layered controlled) Phillips CK
- 12 Philips Colorblast TRX

See plot for configuration

EFFECTS:

- 2 Chauvet Vesuvio RBGAs
- 4 Chauvet Strike 4 LEDs
- 1 36" mirror ball with motor
- 2 LA MaTtre Radiance Touring Haze System
- 2 Antari Ice low lying fog machines
- 2 Chauvet Geyser RGB
- 2 LA Maltre Silent Storm snow machines

DIMMING:

- 2 24-channel 2.4 w ETC Senor racks (total 48 channel)
- 2 Elation Pro Cyber packs

FOLLOW SPOTS: 2 Lucien 1275 follow spots

Spots are located on balcony level at rear of house on platform center to stage.

LIGHTING PLOT

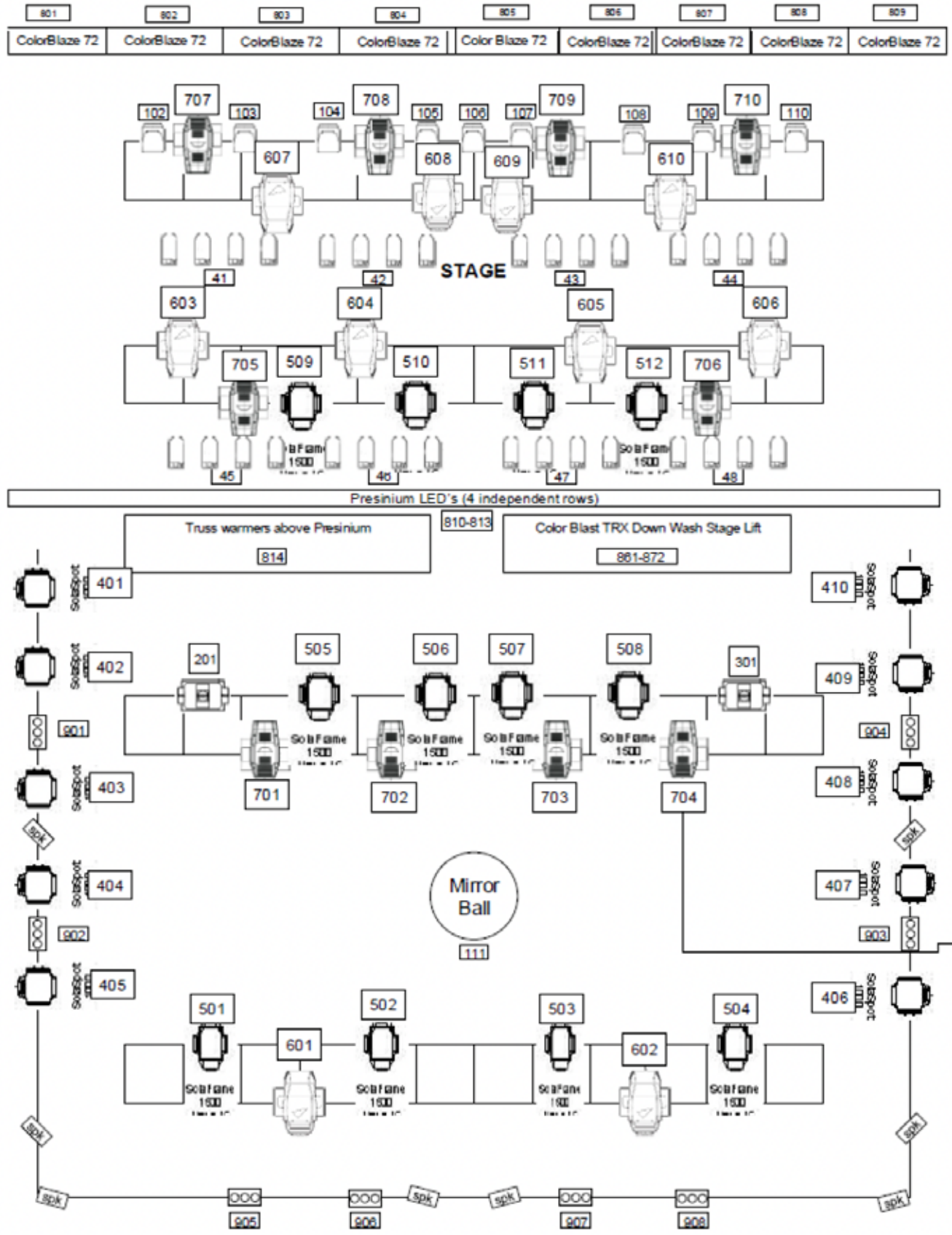

LIGHTING PATCH INFORMATION

REVISION 8-20-2021

User #	Fixture Type	Universe	DMX Address
601	Martin Mac Viper AirFX Ext Mode	1	1
602	Martin Mac Viper AirFX Ext Mode	1	29
603	Martin Mac Viper AirFX Ext Mode	1	57
604	Martin Mac Viper AirFX Ext Mode	1	85
605	Martin Mac Viper AirFX Ext Mode	1	113
606	Martin Mac Viper AirFX Ext Mode	1	141
607	Martin Mac Viper AirFX Ext Mode	1	169
608	Martin Mac Viper AirFX Ext Mode	1	197
609	Martin Mac Viper AirFX Ext Mode	1	225
610	Martin Mac Viper AirFX Ext Mode	1	253
701	High End Systems Techno Arc	1	281
702	High End Systems Techno Arc	1	302
703	High End Systems Techno Arc	1	323
704	High End Systems Techno Arc	1	344
705	High End Systems Techno Arc	1	365
706	High End Systems Techno Arc	1	386
707	High End Systems Techno Arc	1	407
708	High End Systems Techno Arc	1	428
709	High End Systems Techno Arc	1	449
710	High End Systems Techno Arc	1	470
111	Non Dim / Mirror Ball	1	491
User #	Fixture Type	Universe	DMX Address
501	High End Systems Sola Frame 1500	2	1
502	High End Systems Sola Frame 1500	2	49
503	High End Systems Sola Frame 1500	2	97
504	High End Systems Sola Frame 1500	2	145
505	High End Systems Sola Frame 1500	2	193
506	High End Systems Sola Frame 1500	2	241
507	High End Systems Sola Frame 1500	2	289
508	High End Systems Sola Frame 1500	2	337
509	High End Systems Sola Frame 1500	2	385
510	High End Systems Sola Frame 1500	2	433
1001	Desk Channel /Hazer	2	481
1002	Desk Channel /Hazer	2	482
1101	Desk Channel/ Snow Machine	2	483
1102	Desk Channel/ Snow Machine	2	484
1201	Desk Channel / Low Fog	2	485
1501	Chauvet Vesuvio	2	486

User #	Fixture Type	Universe	DMX Address
511	SolaFrame 1500	3	1
512	SolaFrame 1500	3	49
48	Desk Channel ACL	3	97
2	Desk Channel	3	98
3	Desk Channel	3	99
4	Desk Channel	3	100
5	Desk Channel	3	101
44	Desk Channel ACL	3	103
43	Desk Channel ACL	3	104
42	Desk Channel ACL	3	105
41	Desk Channel ACL	3	106
102	Color Command Intensity	3	109
103	Color Command Intensity	3	110
104	High End Systems Color Command Intensity	3	111
105	High End Systems Color Command Intensity	3	112
106	High End Systems Color Command Intensity	3	113
107	High End Systems Color Command Intensity	3	114
108	High End Systems Color Command Intensity	3	115
109	High End Systems Color Command Intensity	3	116
110	High End Systems Color Command Intensity	3	117
47	Desk Channel ACL	3	118
46	Desk Channel ACL	3	119
45	Desk Channel ACL	3	120
101	High End Systems Color Power	3	121
110	High End Systems Color Command Fixture	3	122
109	High End Systems Color Command Fixture	3	126
108	High End Systems Color Command Fixture	3	130
107	High End Systems Color Command Fixture	3	134
106	High End Systems Color Command Fixture	3	138
105	High End Systems Color Command Fixture	3	142
104	High End Systems Color Command Fixture	3	146
103	High End Systems Color Command Fixture	3	150
102	High End Systems Color Command Fixture	3	154
801	Generic RGB/CYC	3	181
802	Generic RGB/CYC	3	184
803	Generic RGB/CYC	3	187
804	Generic RGB/CYC	3	190
805	Generic RGB/CYC	3	193
806	Generic RGB/CYC	3	196
807	Generic RGB/CYC	3	199
808	Generic RGB/CYC	3	202
809	Generic RGB/CYC	3	205
810	Generic RGB/CYC	3	208
811	Generic RGB/CYC	3	211
812	Generic RGB/CYC	3	214
813	Generic RGB/CYC	3	217

User #	Fixture Type	Universe	DMX Address
814	Generic RGB/CYC	3	220
815	Generic RGB/CYC	3	223
816	Generic RGB/CYC	3	226
817	Generic RGB/CYC	3	229
818	Generic RGB/CYC	3	232
819	Generic RGB/CYC	3	235
820	Generic RGB/CYC	3	238
821	Generic RGB/CYC	3	241
822	Generic RGB/CYC	3	244
823	Generic RGB/CYC	3	247
824	Generic RGB/CYC	3	250
825	Generic RGB/CYC	3	253
826	Generic RGB/CYC	3	256
827	Generic RGB/CYC	3	259
828	Generic RGB/CYC	3	262
829	Generic RGB/CYC	3	265
830	Generic RGB/CYC	3	268
831	Generic RGB/CYC	3	271
832	Generic RGB/CYC	3	274
833	Generic RGB/CYC	3	277
834	Generic RGB/CYC	3	280
835	Generic RGB/CYC	3	283
836	Generic RGB/CYC	3	286
837	Generic RGB/CYC	3	289
838	Generic RGB/CYC	3	292
839	Generic RGB/CYC	3	295
840	Generic RGB/CYC	3	298
841	Generic RGB/CYC	3	301
842	Generic RGB/CYC	3	304
843	Generic RGB/CYC	3	307
844	Generic RGB/CYC	3	310
845	Generic RGB/CYC	3	313
846	Generic RGB/CYC	3	316
847	Generic RGB/CYC	3	319
848	Generic RGB/CYC	3	322
849	Generic RGB/CYC	3	325
850	Generic RGB/CYC	3	328
851	Generic RGB/CYC	3	331
852	Generic RGB/CYC	3	334
853	Generic RGB/CYC	3	337
854	Generic RGB/CYC	3	340
855	Generic RGB Arch 1	3	343
856	Generic RGB Arch 2	3	346
857	Generic RGB Arch 3	3	349
858	Generic RGB Arch 4	3	352
859	Generic RGB Arch Truss	3	355

User #	Fixture Type	Universe	DMX Address
861	Color Kinetics Color Blast TRX Norm 8 bit	3	430
862	Color Kinetics Color Blast TRX Norm 8 bit	3	435
863	Color Kinetics Color Blast TRX Norm 8 bit	3	440
864	Color Kinetics Color Blast TRX Norm 8 bit	3	445
865	Color Kinetics Color Blast TRX Norm 8 bit	3	450
866	Color Kinetics Color Blast TRX Norm 8 bit	3	455
867	Color Kinetics Color Blast TRX Norm 8 bit	3	460
868	Color Kinetics Color Blast TRX Norm 8 bit	3	465
869	Color Kinetics Color Blast TRX Norm 8 bit	3	470
870	Color Kinetics Color Blast TRX Norm 8 bit	3	475
871	Color Kinetics Color Blast TRX Norm 8 bit	3	480
872	Color Kinetics Color Blast TRX Norm 8 bit	3	485
1601	Chauvet Strike 4 - 4 channel mode	3	490
1602	Chauvet Strike 4 - 4 channel mode	3	494
1603	Chauvet Strike 4 - 4 channel mode	3	498
1604	Chauvet Strike 4 - 4 channel mode	3	502
User #	Fixture Type	Universe	DMX Address
401	High End Systems SolaSpot Pro 1000	4	1
402	High End Systems SolaSpot Pro 1000	4	40
403	High End Systems SolaSpot Pro 1000	4	79
404	High End Systems SolaSpot Pro 1000	4	118
405	High End Systems SolaSpot Pro 1000	4	157
406	High End Systems SolaSpot Pro 1000	4	196
407	High End Systems SolaSpot Pro 1000	4	235
408	High End Systems SolaSpot Pro 1000	4	274
409	High End Systems SolaSpot Pro 1000	4	313
410	High End Systems SolaSpot Pro 1000	4	352
411	High End Systems SolaSpot Pro 1000	4	391
412	High End Systems SolaSpot Pro 1000	4	430
901	Chauvet Colorado 3 m1 Pit Rail	4	469
902	Chauvet Colorado 3 m1 Back Rail	4	481
1401	Desk Channel	4	493
1402	Desk Channel	4	494
1403	Desk Channel	4	495
1404	Desk Channel	4	496
1405	Desk Channel	4	497
1406	Desk Channel	4	498
1407	Desk Channel	4	499
1408	Desk Channel	4	500
1409	Desk Channel	4	501
1410	Desk Channel	4	502
1411	Desk Channel	4	503
1412	Desk Channel	4	504
1413	Desk Channel	4	505
1414	Desk Channel	4	506
1415	Desk Channel	4	507
1416	Desk Channel	4	508

User #	Fixture Type	Universe	DMX Address
911	Chauvet Colorado 3 M1 Columns	7	1
912	Chauvet Colorado 3 M1 Columns	7	13
913	Chauvet Colorado 3 M1 Columns	7	25
914	Chauvet Colorado 3 M1 Columns	7	37

BUILDING AND FIRE CODE

MotorCity Casino Hotel follows the Building and Fire Codes as outlined by the City of Detroit and the State of Michigan. MotorCity Casino Hotel in its sole discretion has the right to not permit specific equipment usage if such use is deemed unsafe or questionable for safety and code reasons. The following MotorCity Casino Hotel policies apply:

The use of any type of pyrotechnics is NOT permitted.

Fire/Flame devices of any type are NOT permitted.

Hazers/foggers/smoke will be operated at the discretion of MotorCity Casino Hotel. Only water-based products are approved for use in Sound Board.

Fire permits are, at times, required by the City of Detroit for specific events. MotorCity Casino Hotel will confirm requirement upon advance. City permitting must be scheduled a minimum of three weeks prior to the event.

Electrical permits are, at times, required by the City of Detroit for specific events. MotorCity Casino Hotel will confirm such requirement upon advance. City permitting must be scheduled a minimum of three weeks prior to the event.

Rigging, when permitted, requires approval by MotorCity Casino Hotel, as well as plan review and approval from a designated MotorCity Casino Hotel engineering firm. Plan submission is required a minimum of one month prior to the event date. Costs associated with the engineering plan review are the sole responsibility of the artist/event.

Streamer cannons are permitted but require advance approval by MotorCity Casino Hotel. Confetti cannons are NOT permitted.

Helium balloons, when permitted, must be professionally secured at all times.

All decorations must have a fire certificate on file prior to use at MotorCity Casino Hotel.

Hanging decorations and associated fixtures require safety cabling provided by the event producer.

Detroit Fire Department approval is required, in advance, in addition to MotorCity Casino Hotel advance approval, when vehicles are to be driven on property. City permitting must be scheduled a minimum of three weeks prior to the event. All vehicles must meet fire code.

Vehicles displayed on property, when permitted by MotorCity Casino Hotel, must maintain all fire code regulations.

Please contact us regarding policies.

MOTORCITY CASINO HOTEL PROPERTY MAP

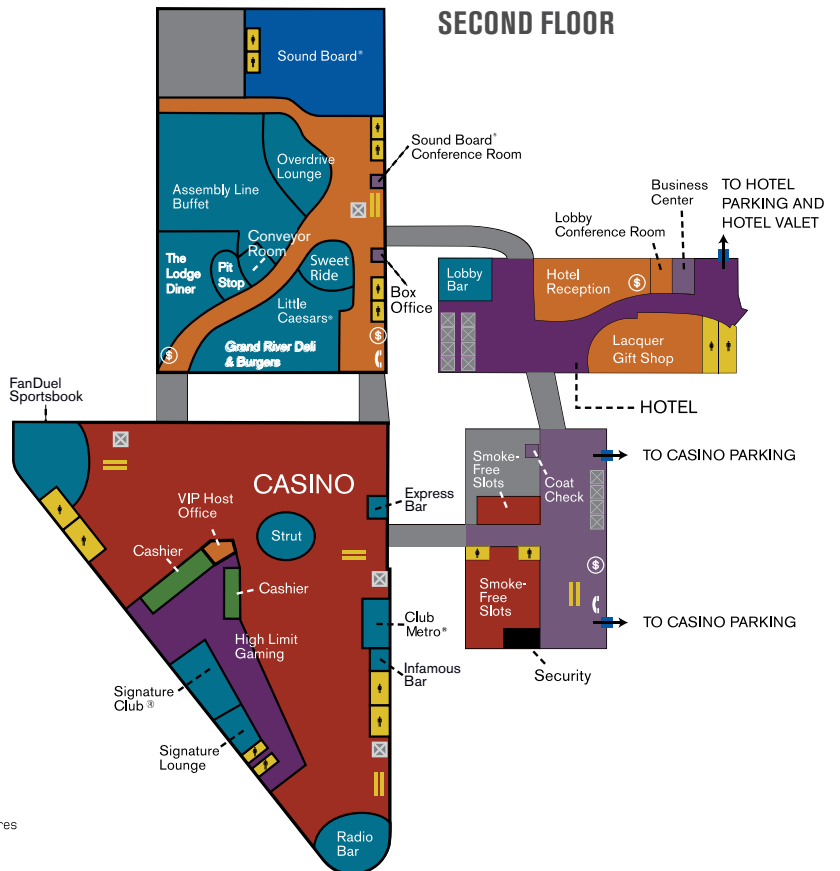
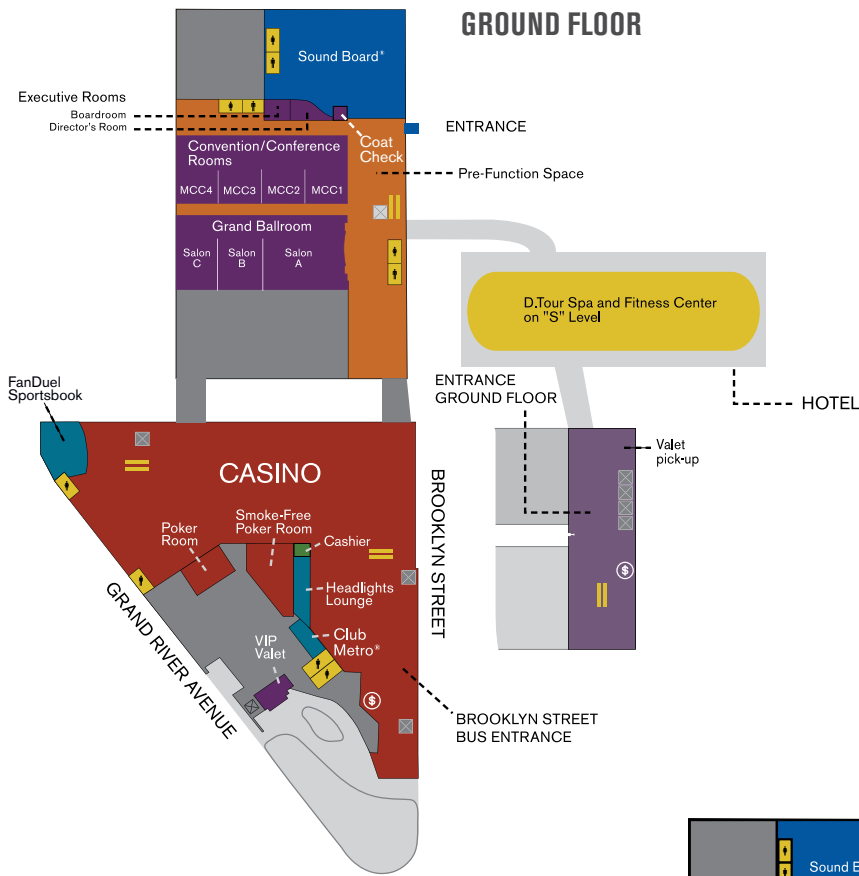

- Ⓢ ATM
- ⊠ Elevator
- ⏮ Escalator
- ☎ Pay Phones
- Casino
- Restaurant
- Bridge
- Cashier
- Restaurant/Bar
- Second Floor Structures

EXTERIOR PROPERTY MAP

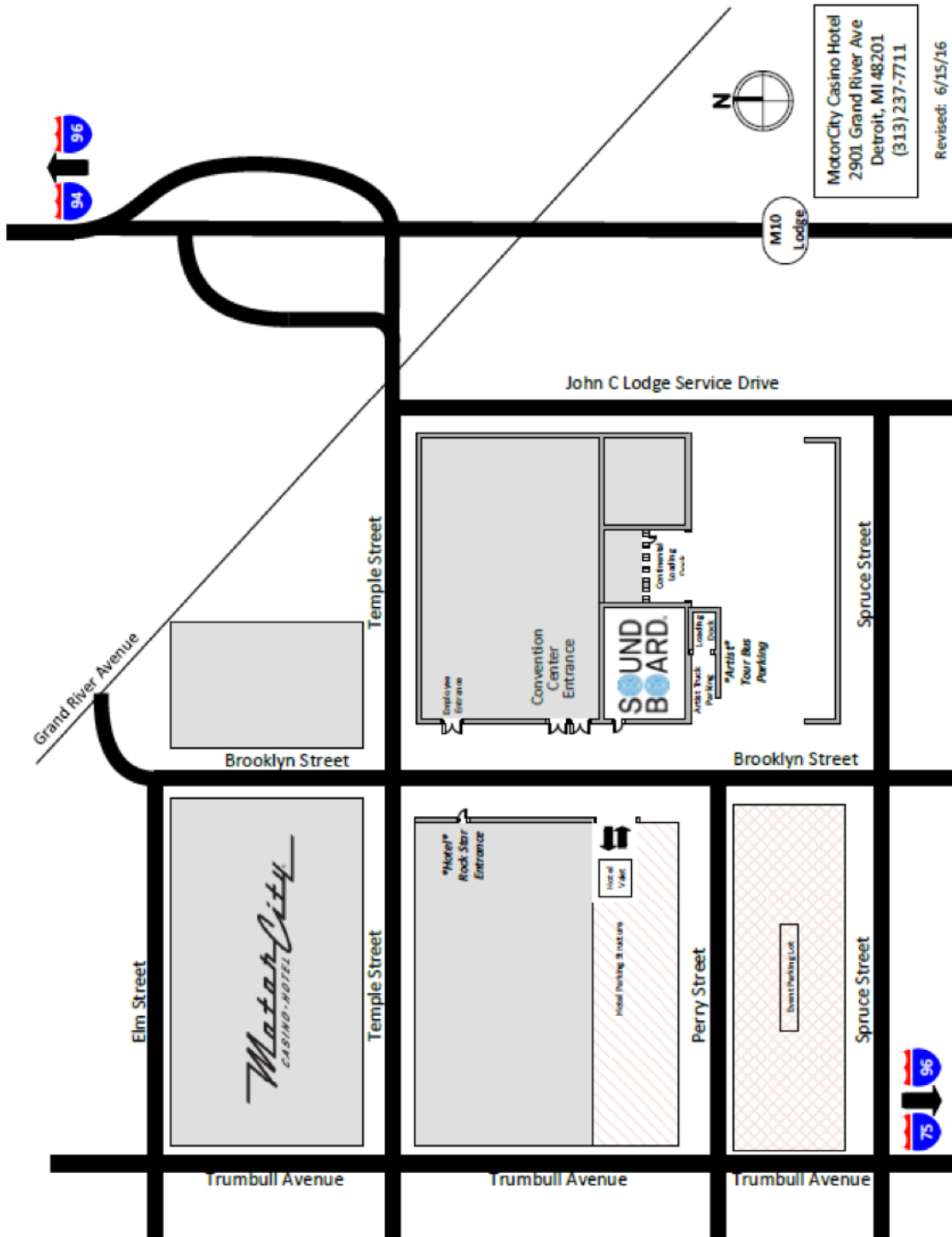

ARTIST PARKING INFORMATION

Artist Parking Information

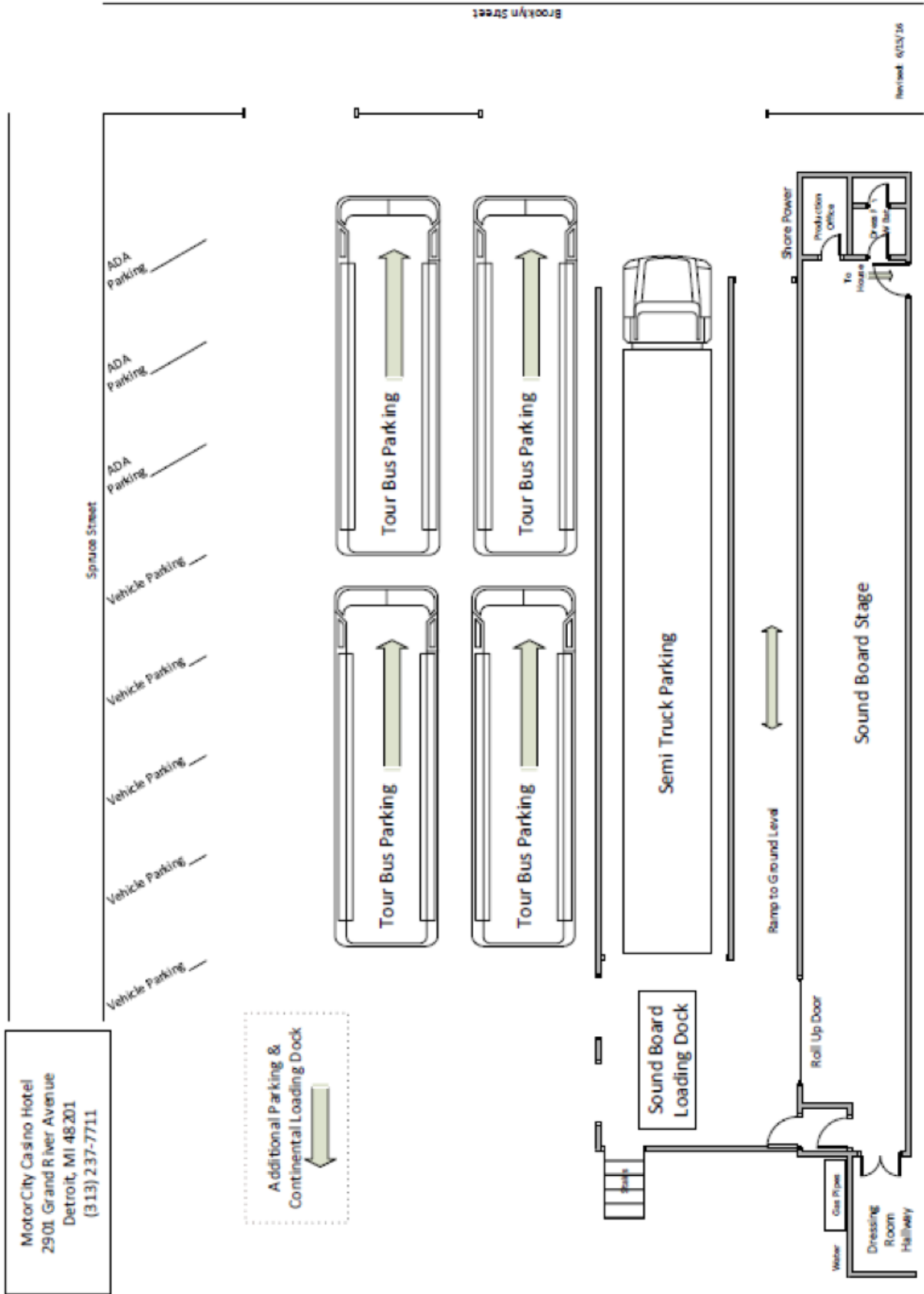

DETROIT AREA MAP

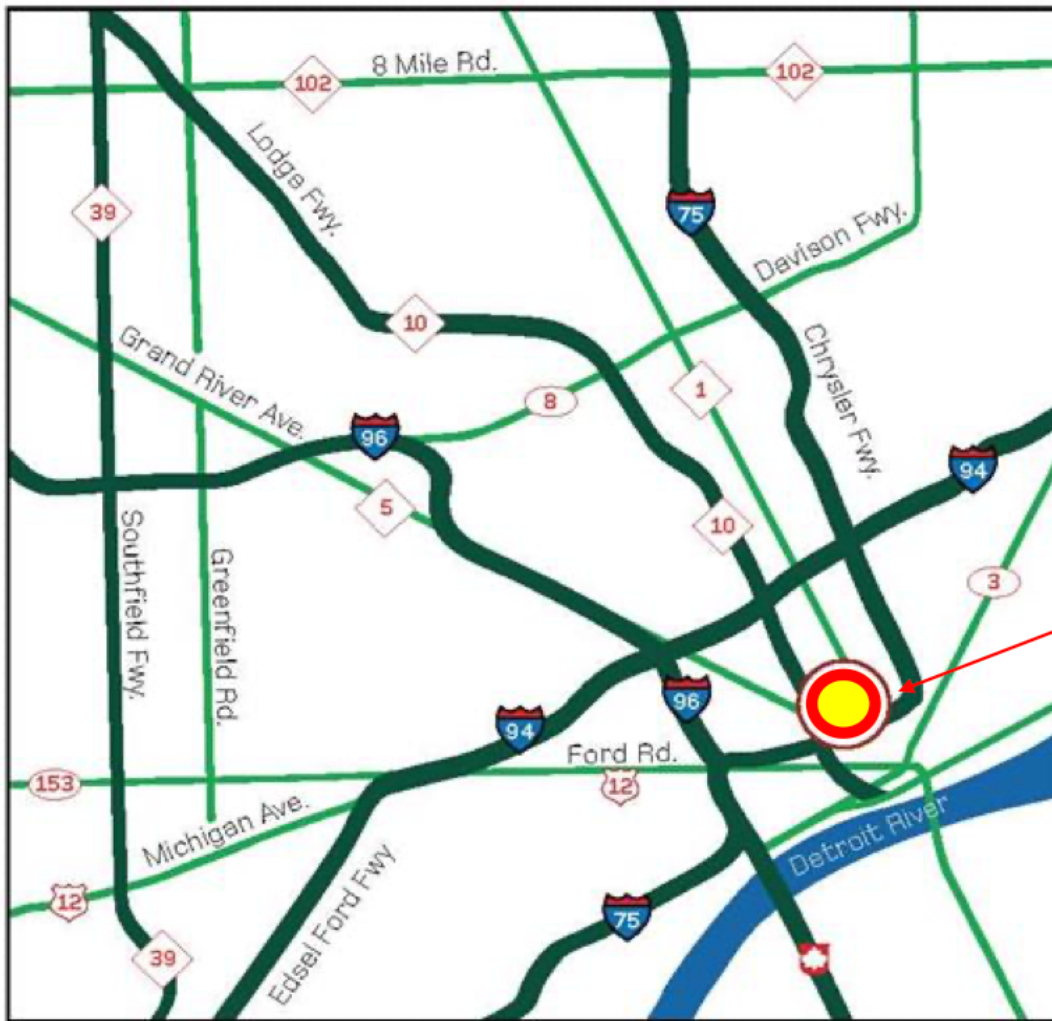

Matar City
CASINO-HOTEL

Directions

FROM THE EAST/CITY AIRPORT: I-94 West to M-10 (Lodge Freeway) South. Exit M-10 at Grand River Avenue.

FROM THE WEST/METRO AIRPORT: From I-96 East exit I-94 East. Exit southbound on M-10 (Lodge Freeway). Exit M-10 at Grand River.

FROM METRO AIRPORT: Take I-94 East to Southbound M-10. Exit M-10 at Grand River.

FROM THE NORTH: I-75 to Davison Fwy West. Merge onto M-10 south (Lodge Fwy). Exit at Grand River.

FROM THE SOUTH: I-75 north to Clark exit. Turn right on Clark, then immediate left at Fort St. North on Fort St. for 1.5 miles, then left on Trumbull, right on Temple.

AIRPORTS

Detroit, Michigan has two airports.

DETROIT METROPOLITAN AIRPORT (DTW)

William G. Rogell Drive
Detroit, Michigan 48212
(734) 247-7678
metroairport.com

Airport Police: (734) 942-5212

TERMINALS:

Air Canada

888-247-2262 North Terminal

Air France

800-237-27 47 McNamara Terminal

Alaska Airlines

800-252-7522 North Terminal

American

800-433-7300 North Terminal

Delta

800-221-1 212 McNamara Terminal

Frontier

800-432-1359 North Terminal

Jet Blue

800-538-2583 North Terminal

Lufthansa

800-645-3880 North Terminal

Royal Jordanian

212-949-0050 North Terminal

Southwest

800-435-9792 North Terminal

Spirit

855-728-3555 North Terminal

United

800-864-8331 North Terminal

WOW air

888-209-3170 North Terminal

Detroit Metropolitan Airport (DTW) General Aviation: There are two fixed base operators at Detroit Metropolitan Wayne County Airport (DTW) that provide services for private and corporate aircraft. Services include cabin cleaning, fueling, hangars, tie-downs, passenger services, and repairs.

For more information of general aviation services at DTW please contact Signature Flight Support DTW at (734) 741-7880 or visit <https://www.signatureflight.com/locations/DTW>

COLEMAN A. YOUNG INTERNATIONAL AIRPORT (DET)
(Formerly Detroit City Airport)
11499 Conner
Detroit, Michigan 48213
(313) 628-21 46
E-Mail: detroitairport@detroitmi.gov

AIRPORT-RELATED SITES:

U.S. Department of Immigration - ins.usdoj.gov
U.S. Department of Customs - customs.ustreas.gov
Federal Aviation Administration - faa.gov
Transportation Security Administration - tsa.gov

AREA TOURISM SITES

Detroit Metro Convention and Visitors Bureau visitdetroit.com
State of Michigan: michigan.org

PROFESSIONAL SPORTS TEAMS

Detroit Red Wings - detroitredwings.com
Detroit Tigers - detroit.tigers.mlb.com
Detroit Lions - detroitlions.com
Detroit Pistons - nba.com/gistons

For complete Michigan sports team listings: detroitsgorts.org



MotorCity
CASINO · HOTEL

MotorCityCasino.com | 866-STAY-MCC



If you bet more than you can afford to lose, you've got a problem. Call 1-800-270-7117 for free, confidential help.

MotorCity Casino Hotel and MotorCity Casino Hotel design are trademarks of Detroit Entertainment, L.L.C. ©2022 Detroit Entertainment, L.L.C. All rights reserved.